

Realize Security Visualization for Your Large-Scale Networks

- **Application** Factory Automation
- **Industry** Manufacturing
- **Region** USA

Introduction

A manufacturer of automotive parts in the U.S.A. wanted to digitalize their production processes. However, the industrial control networks were built a long time ago and expanded overtime to meet increased production capacity requirements. It became a challenge for the company to effectively manage all of the devices.

System Requirements

The field devices run on the EtherNet/IP protocol for control unification and data acquisition. As this plant required a large-scale network infrastructure, it was very difficult for the plant manager to monitor all devices and visualize the network topologies. In addition, in order to achieve digitization, the networks had to be interconnected from the field site all the way to the ERP and even to the cloud. It is essential to have good cybersecurity measures in place to allow this transformation to occur, and importantly, without compromising production efficiency.

Moxa Solution

Moxa helped the company replace its switches with managed switches so that they support EtherNet/IP multicast filtering and advanced security functions. In addition, the company utilized our MXview network management software for real-time monitoring and visualization of the industrial control networks.

Pro Tips

The combination of managed switches and network management software is the ideal solution to provide advanced security features and real-time monitoring while also meeting the EtherNet/IP multicast traffic filtering requirements.

Strong Device Security

- Supports the EtherNet/IP protocol and IGMP snooping to manage multicast traffic and reduce jitter
- Offers real-time and visualized central network management and the security status can be viewed at a glance
- Industrial cybersecurity features based on the IEC 62443 standard

MXview
Manufacturing Management Software

MXview
Network Management
Software

Control Center

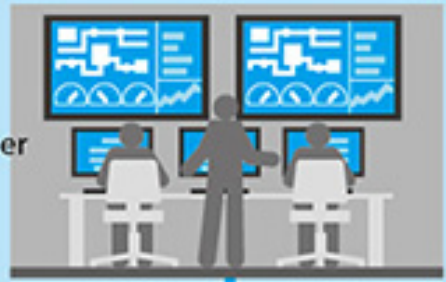

Plant Network



Enterprise Switch

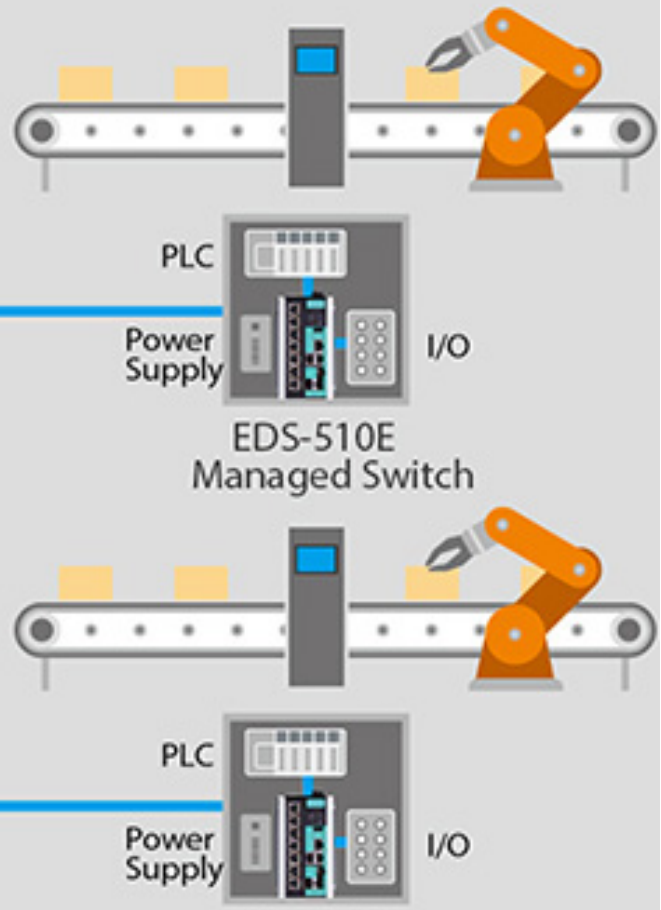
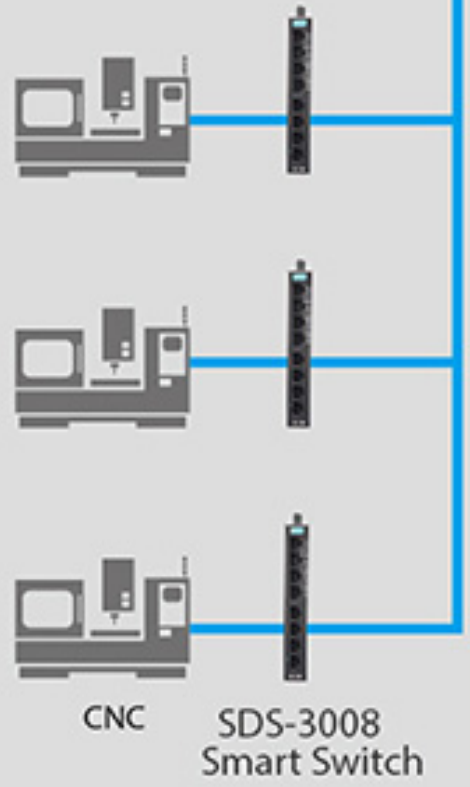

Machine/Production Network

EDS-510E
Managed Switch